

# Flashing

Anticipate the flow of water to keep it outside your house, where it belongs

by Bob Syvanen

**F**lashing is that ounce of prevention worth a pound of cure. I can't begin to count the repair jobs I've done because of faulty flashing. All the mystery was taken out of flashing for me when an old-timer advised that I take a ride on a drop of water as it runs down the roof or sidewall. In so doing, you quickly realize where that drop wants to go, and you understand how to change its direction. Anything that stops the flow will do it. A gutter is a good example. A strong wind will also cause a change in direction, and leaks often result. Other problems oc-

cur at junctures of dissimilar materials, where, for example, a chimney meets a roof or an aluminum window frame joins a sidewall. Any vertical crack is also an open invitation to water—door and window jambs, casings and corner boards.

Flashing used in these and other locations will keep water out of your house. The material used for flashing can be copper, lead, aluminum, galvanized steel, plastic or paper. What material is used where depends on cost, how severe the condition is, and how long it should

last. Copper is the best and the most expensive flashing material. It is strong, long-lasting and can be easily shaped. Lead is right up there in quality and cost; it can be shaped quite easily, but you have to be careful because it punctures and tears. Galvanized (zinc-plated) steel comes next, followed by aluminum, plastic and paper. Unformed metal flashing comes in 10-ft. lengths, in sheets or rolls of various widths and gauges.

*Bob Syvanen is consulting editor to Fine Homebuilding magazine.*

## Make your own

Although sheet-metal shops are equipped with power shears and brakes that produce crisp lines in a hurry, it is often cheaper and quicker to make and fit your own flashings. This will cut down on travel and turn-around time. The one exception is galvanized steel flashings. Because they are so stiff, it is usually better to purchase them preformed.

Most flashings require a 90° fold (1). The easiest way to get one is to bend the flashing material over a sharp wooden corner. Use a 2x6 with its eased edge ripped off. Then set up a simple jig (2), with nails set along a guide line to position the metal quickly for bending. For narrow bending, a pair of wide-jawed, lock-grip pliers is useful (3). Thin-gauge metal flashing can be cut easily with a sharp utility knife. For heavier metals use tin snips (4) or aviation snips (5) for even easier cutting.

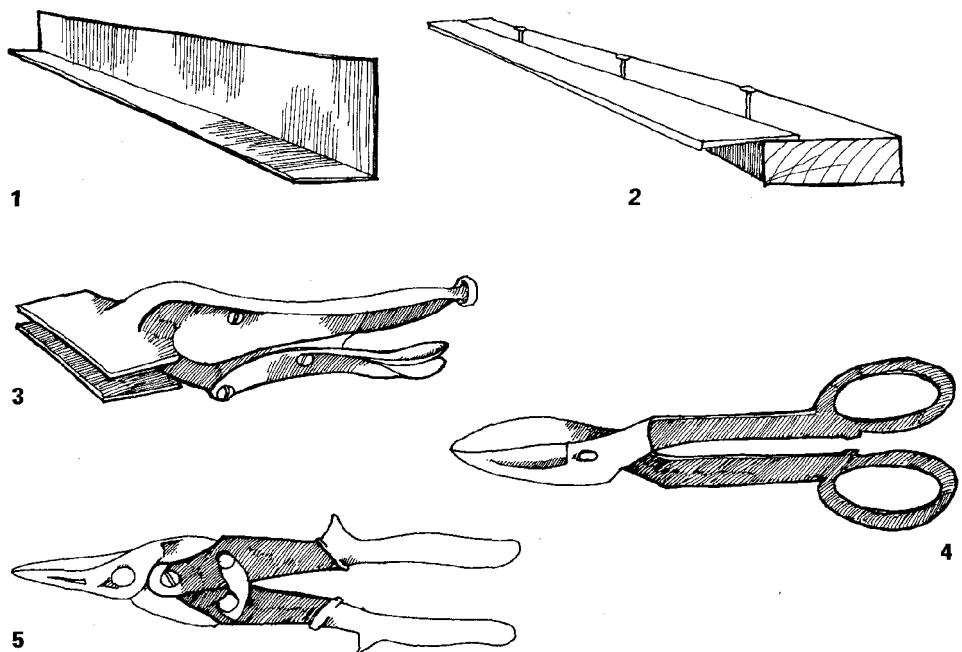

## Doors and windows

I like to flash window sills with paper, but I use metal on door sills (6), because doors have moisture problems with snow, rain, wet leaves and the like. With window sills, tuck the flashing up into the groove that receives the siding (7). For door and window jambs, flashing paper or 15-lb. felt, 6 in. or more in width, is stapled around the frame (8). The siding felt is tucked underneath this flashing. Make sure that these paper splines run over the sill flashing, which overlays the siding paper. For shingle siding, the sill flashing and the bottom of the jamb spline should overlap the tops of a shingle course, and then be covered by the two remaining courses of shingles underneath the window sill (9). This way the felt won't show through.

Window and door headers must also be flashed, and for this, I think thin metal is best. Nail it in place, keeping the nails high, and continue with the siding. Let the siding felt lap over this head flashing (10). After the siding is on, the  $\frac{1}{2}$  in. overhang can be bent over the head casing, using a 2x4 block about 1 ft. long (11). Finish it off by holding the block against the flashing and beating it with a hammer to make a nice flat surface (12).

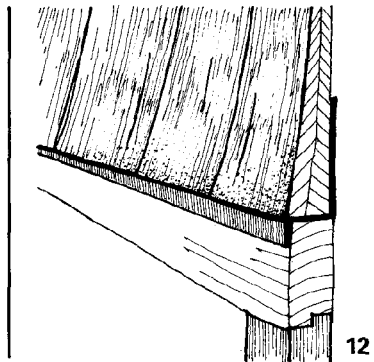
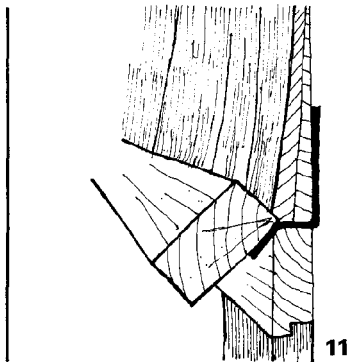
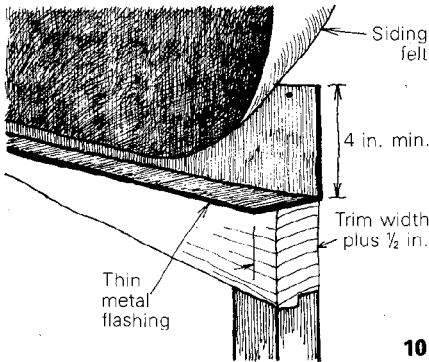
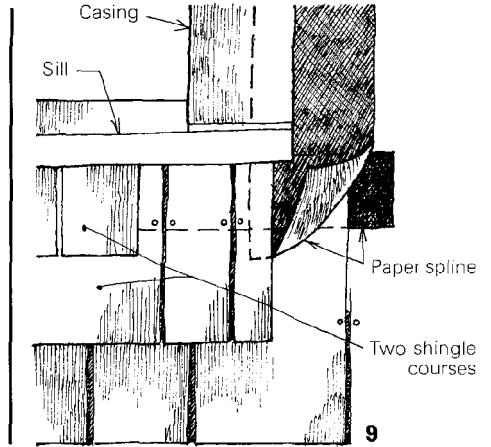
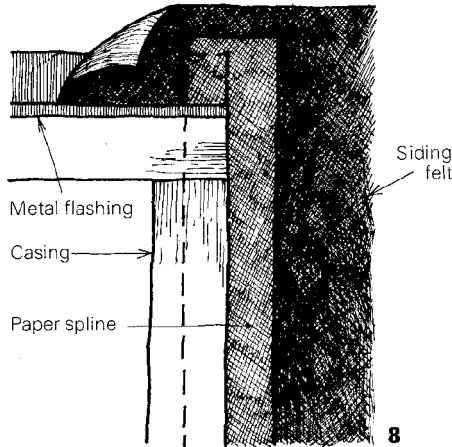
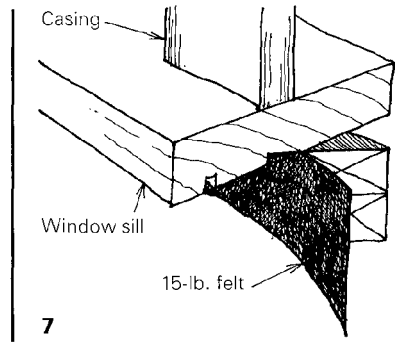
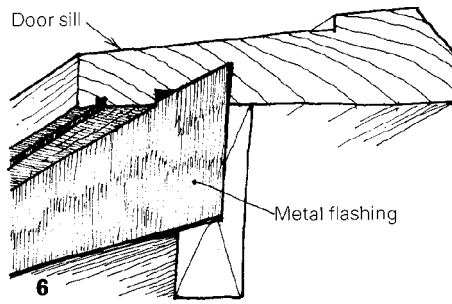

## Gutters

Another kind of flashing that is made most easily on the job protects wood gutters. Gutter ends that butt against a rake board must be flashed with an oversized piece of lead (13). The flashing can be coaxed into place by gentle tapping with the end of a rubber-handled hammer. The final trimming can be done after the flashing is formed. A wide bed of caulking on the lead edge will seal it, and copper tacks hold it in place. A gutter splice (14) is leaded the same way, but there are no compound curves.

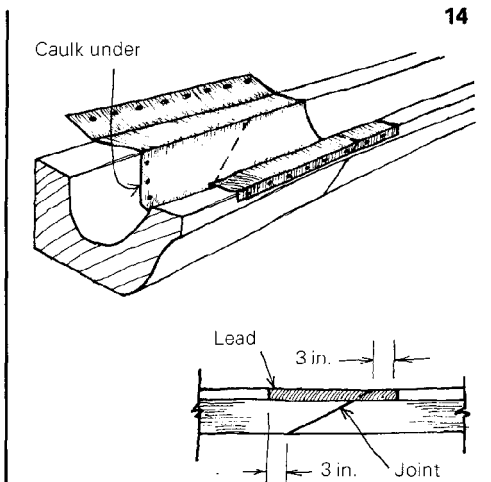
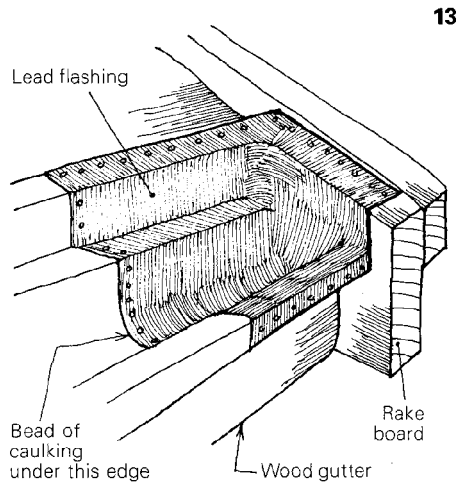

## Wall and wall-to-roof junctures

Brick-veneer walls require flashing at their bases to keep water away from the wood framing (15). Where a sheet of plywood butts another, the flashing for a horizontal seam is similar to that over a window (16). It is called Z-flashing, and is typically preformed aluminum or galvanized metal in 10-ft. lengths.

Flashing an attached shed roof is hard to do right, and a prevailing wind makes it even tougher (17). Flashing at the peak of a freestanding shed is quite simple (18). One of the toughest conditions to flash is where a pitched roof butts into a wall (19),

but with careful work, water can be kept out. Where a shed roof tucks into an inside corner, the answer is a copper-flashed, tapered cant strip (20).

Step-flash where a roof meets a sidewall (21). Each roof shingle course requires a separate flashing shingle underneath, so I take a roll of galvanized steel, aluminum or copper and cut enough 8-in. squares to do the job. Fold each one 90° over a wood block, and they are ready to nail up. The shingle exposure is typically 5 in., so an 8-in. step-flashing shingle will give you a 3-in. overlap. To keep the shingles in place, nail their upper corners only.

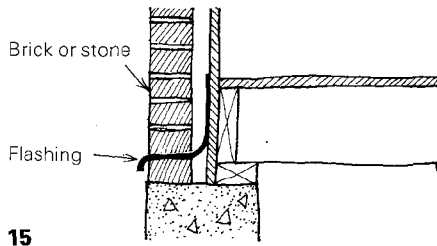

15

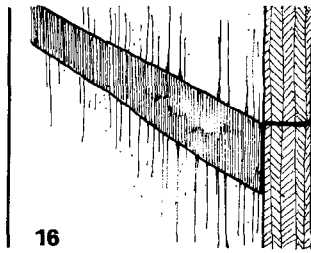

16

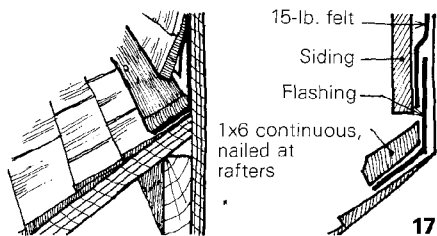

17

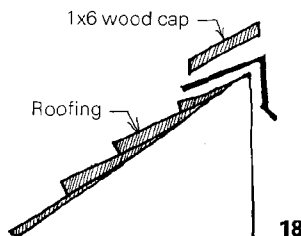

18

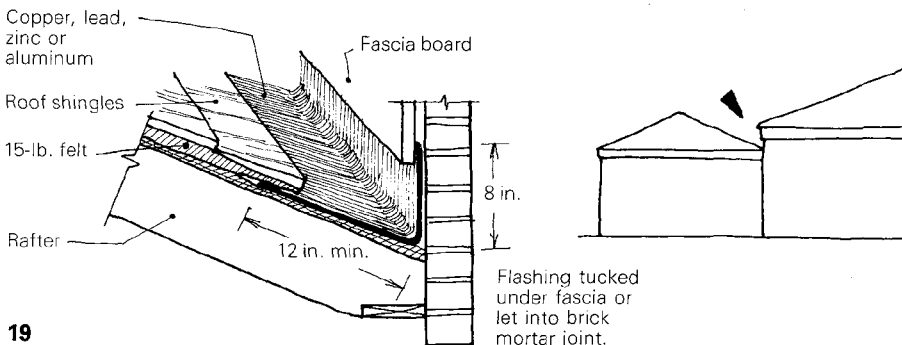

19

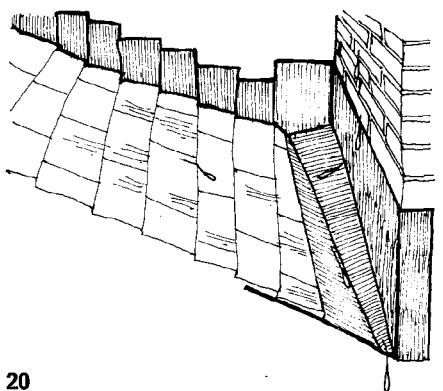

20

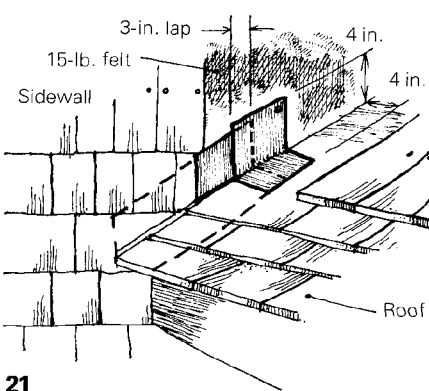

21

## Chimneys

I think chimneys cause almost as much damage as floods. It's a miracle when they don't leak, sitting up there, buffeted by wind and rain, with at least one big hole on top. The hole on top can be protected with a stone cap, but this doesn't always look good. The very best flashing is thru-pan flashing, and copper is the best material (22). The pan redirects water that gets in at the chimney top. The roof shingles are base-flashed and step-flashed. The brick is cap-flashed over the tops of the base and step flashing (23). Another common system is to incorporate base flashing and cap flashing with each piece of the step flashing.

Another thru-pan system uses one large lead sheet with a hole cut for the flue, and carefully formed and folded to lie flat over the masonry and on the roof (24).

For chimneys less than 2 ft. wide, a simple flashing bent to the roof pitch will shed rain and snow (25). If the chimney is wider, a cricket is the best solution. It can be a one-piece sheet-metal cricket if it's not too wide (26). A wood-framed cricket can be built for wide chimneys, and handled just like a dormer roof (27).

## Beams

For exterior decks, pressure-treated lumber is best, but if untreated lumber is used, flashing the deck beams will help prevent water damage (28). Intersecting beams should be cap-flashed (29). A beam projecting from a sidewall should be flashed and capped (30), particularly if it is a two-piece beam. Water just loves to sit in that crack between the beams. This solution takes care of the top, but shrinkage at the sides makes caulking the best way to seal this joint. A better solution (31), although not cheap, requires soldering of all joints.

Members fastened to the sidewall are flashed the same way as windows (32). A post through a flat roof is no problem if it is flashed (33). The tops of untreated posts, if left flat, will suck up water like a sponge. Sloping the top will help. A better way is to cap-flash the top. This used to be common practice.

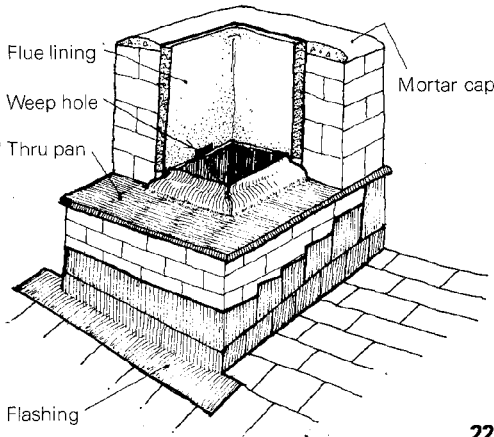

22

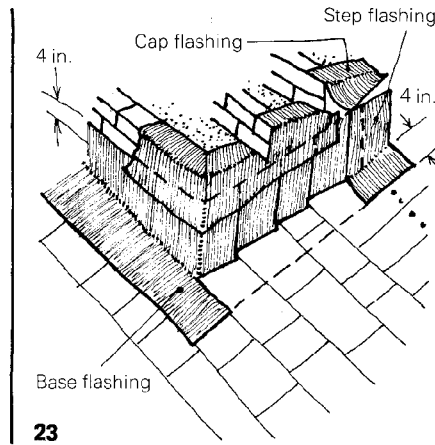

23

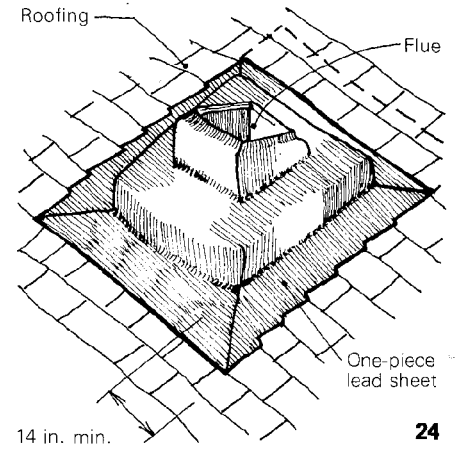

24

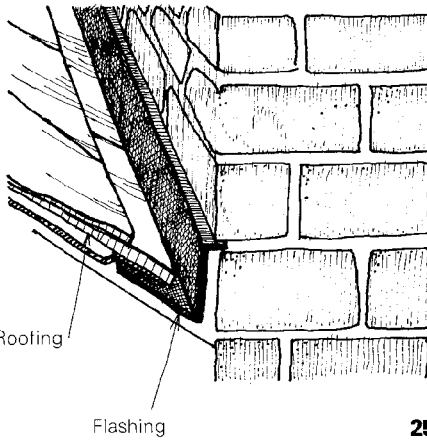

25

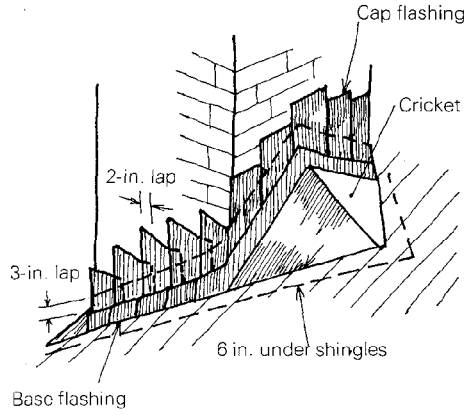

26

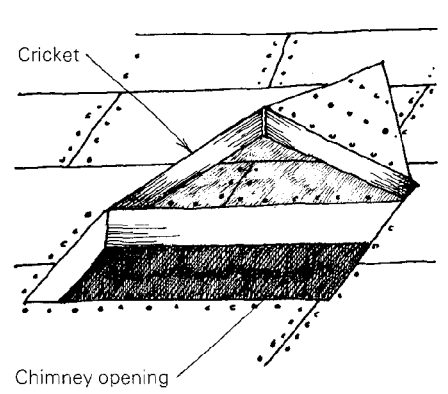

27

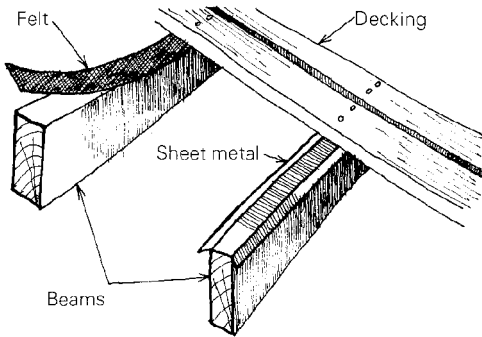

28

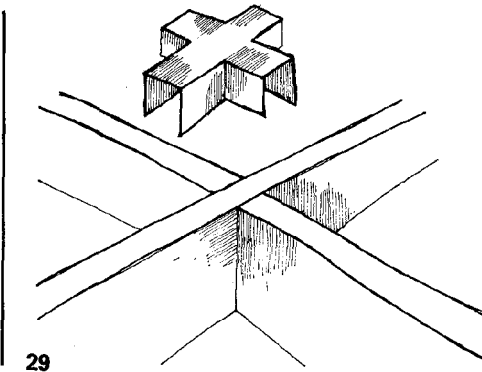

29

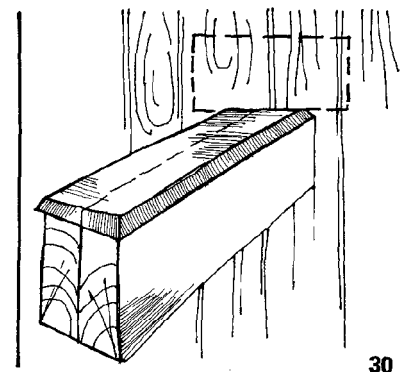

30

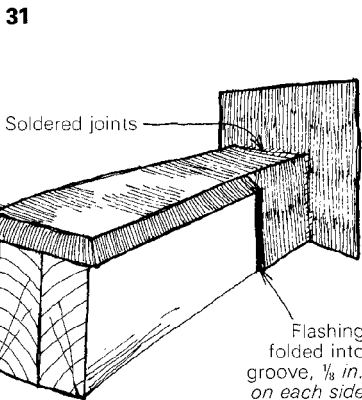

31

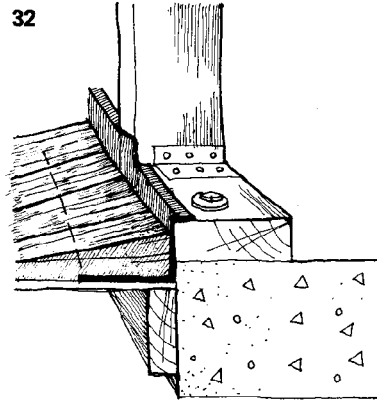

32

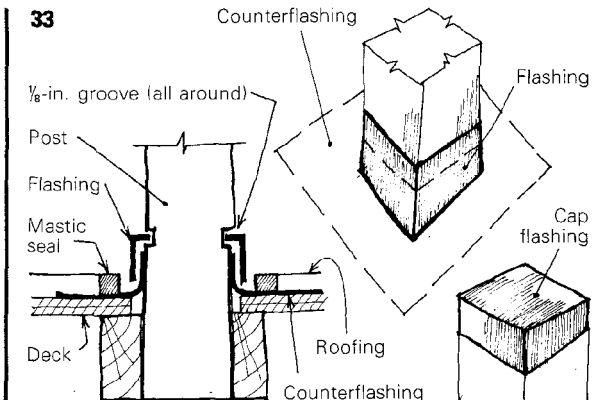

33

## Roofs

Since the neoprene sleeve came on the scene, roof stacks have become easy to weatherproof. You just select the right-sized flange, slide it on the stack, and shingle around it (34). If the roof is wood shingled, check for splits that might leak. If there are any cracks that line up, slip a 2-in. by 8-in. flashing strip, sometimes called a tin shingle, under the split (35). I consider this part of the job whenever a roof is shingled.

Another tough area to flash is a valley. There are basically two kinds: open valleys and closed valleys (36). I like the look of the closed valley, but it is more work. The closed valley starts with a base of 30-lb. felt its full length. The shingles, whether wood or asphalt, are laid to a chalkline snapped up the middle of the felt. The flashings are 12-in. squares of zinc, aluminum or copper, folded diagonally to fit the valley (37). The first piece is a rough half piece. Each shingle course gets one piece held in place with a nail in one outer corner. The shingles are then angle-cut for a nice tight fit.

The open valley is just what it says: open. The valley material can be 90-lb. roofing felt, or copper or galvanized steel. Ninety-lb. roofing felt makes a fine valley if it's installed in two layers (38). Always watch for nails falling into the valley as you work, and keep it clean. The valley should be 5 in. or 6 in. wide (39). It looks better if the valley is the same width on top and bottom, but some recommend widening the bottom to take care of the increase of water. Take your pick, but be sure to cut off the upper inside corner of the asphalt shingles. If the tip is left on, it will catch water, which will ride down the upper edge of the shingle course until it finds a way out, often 15 or 20 ft. away.

Metal valleys are extremely durable, but more expensive. They can be flat in the center, or crimped (40). Some have dams for severe runoff conditions (41). The valley can be nailed at the edges to keep it in place, or you can use clips every 24 in. o.c. (42).

A caution about mixing metals. Galvanic action can be a problem, so don't combine metals from the opposite ends of the following list: aluminum, zinc, tin, lead, brass, copper, bronze. The safest way to proceed is to use clips or nails of the same metal as the flashing.

There is no need for guesswork in flashing. A little thinking goes a long way toward a good job. Just ride that drop of water through the area to be flashed, and you'll know what to do. □

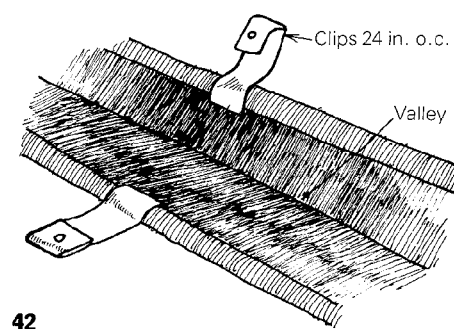
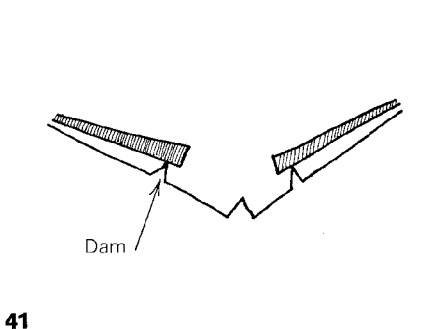
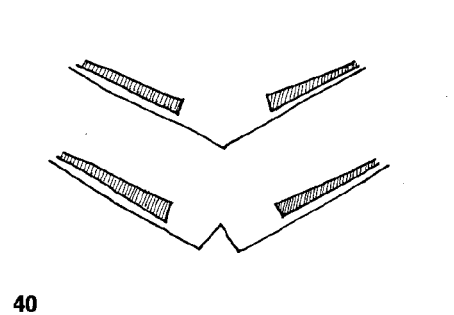
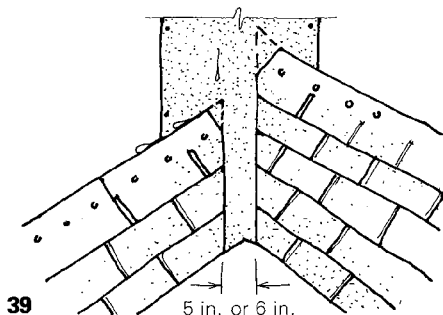
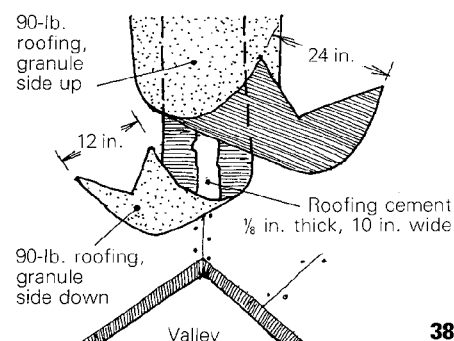
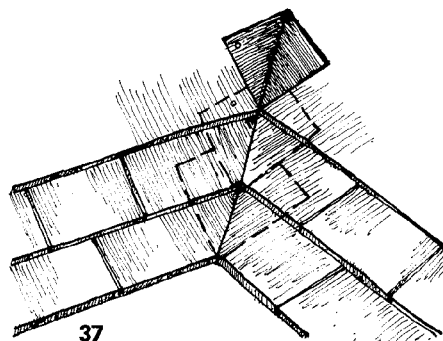
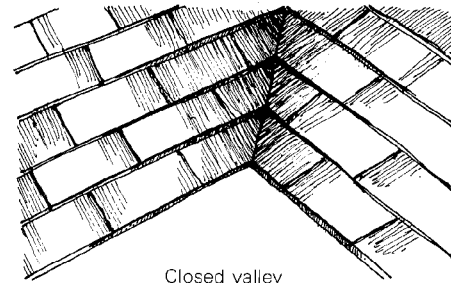
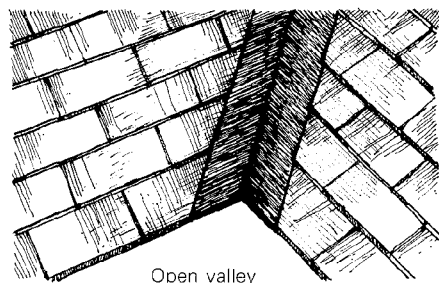
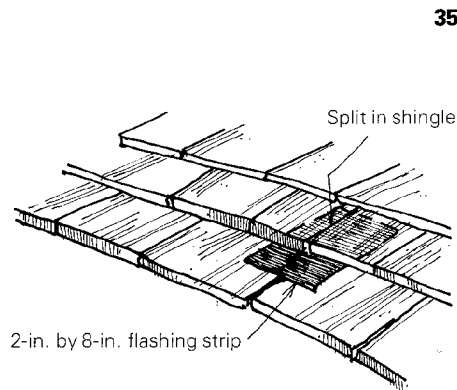
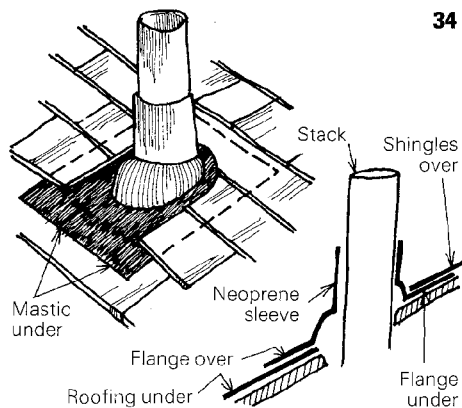

## ERRATA

I found Bob Syvanen's article on flashing (*FHB* #9) most informative, and I will use some of the information myself when I do my next roof. However, as a journeyman carpenter and professional woodworker for some 10 years, I feel some misinterpretations may be drawn from several of the illustrations in that article, and corrections should be noted.

I refer specifically to illustrations #11 and #12, which show how to flash over a window. In the drawings, the siding makes direct contact with the flashing. If wood siding, whether it be shingles, clapboard or plywood, is allowed to rest on or even close to the flashing, several things can happen. Water that lies on the horizontal flashing will be drawn up into the end grain of the shingles by capillary action. This can blacken the wood and lead to rot. If plywood is used for siding, the water it absorbs can cause it to swell, and the subsequent expansion can cause the material to delaminate, or to buckle if it is restricted.

The solution is to hold the siding away from the flashing ( $\frac{1}{4}$  in, or more) so that the water can drip completely off the siding before it wets the flashing.

Illustration #32, which shows how to flash members attached to a sidewall, is not properly oriented on the page. Also, it shows that the siding makes contact with the flashing, something it shouldn't do.

—Paul J. Pieper, Jr., Abington, Pa.

*Editor's note: You are right about drawing #32. It should be rotated 90° clockwise to be read properly.*