

BY A. TAMASIN STERNER
AND LARRY ARMANDA

Unlike pipes, ducts don't hold water, sewage, or flammable gases, so most people don't worry about them leaking. Leaky ducts can cause a host of building problems, however, ranging from cold rooms to a life-threatening buildup of carbon monoxide.

Because HVAC systems use a blower to circulate conditioned air, duct leakage can adversely affect air pressure inside a house, and intensify air infiltration and exfiltration through the building envelope.

At a minimum, leaky ducts mean the air in your HVAC system isn't going where it's supposed to, making it more expensive to operate the system and more difficult to keep your home comfortable.

Fortunately, building codes are finally recognizing that leaky ducts are a problem. The 2006 International Residential Code (IRC) requires (in section M1601.3.1) that "joints of duct systems shall be made substantially airtight by means of tapes, mastics, gasketing, or other approved closure systems." A 2009

Leaky ducts waste energy and contribute to a host of building problems

Testing and Sealing Ductwork

TESTING: Two methods for tracking leaks

1 Pressure-pan tests find leaks

Used in conjunction with a blower door, pressure-pan testing is a fast way to determine if a house's ductwork is leaky. Unfortunately, the test can't quantify the amount of leakage, so it's unsuitable for code-compliance or efficiency testing for programs like LEED and Energy Star.

How much leakage does code allow?

Until recently, the IRC gave little attention to duct sealing, but the 2009 version of the code requires that the joints of duct systems be made substantially airtight. The allowable leakage depends on when the ductwork is tested.

2009 IRC N1103.2.2 (SEALING)

Verify duct tightness with either a postconstruction test or a rough-in test.

1. Postconstruction test

Duct-leakage limits: Leakage to outdoors ≤ 8 cfm per 100 sq. ft. of conditioned floor space, or total leakage ≤ 12 cfm per 100 sq. ft. of conditioned floor space.

2. Rough-in test

Total leakage ≤ 6 cfm per 100 sq. ft. of conditioned floor space. If air handler is not installed, total leakage ≤ 4 cfm per 100 sq. ft. of conditioned floor space. Since a significant amount of leakage can occur at the air handler, plenum, and filter box, this option makes the allowable leakage rate more stringent.





2 Duct-blower tests quantify leaks

Connected to the furnace-blower compartment or a centrally located return grille, duct blowers simulate normal HVAC-system operating pressure. This test can quantify duct-system leakage for compliance with LEED and Energy Star standards.



Fog pinpoints leaks. Forced into the ductwork by the duct blower, theatrical fog can track down both big and small leaks. It's also a good way to silence HVAC installers convinced that their ducts are sufficiently sealed.

IRC provision requires any home with ducts outside the thermal envelope to have them tested for airtightness and to meet certain requirements (sidebar, facing page).

Unfortunately, few HVAC installers pay attention to duct-sealing, and even fewer are familiar with new code requirements. If you're a concerned homeowner, builder, or remodeler, you'll likely have to shepherd testing and sealing efforts yourself.

Duct-testing basics

It's a given that all ducts leak at least a little, but most duct systems leak a lot more than is acceptable.

You can test duct tightness in several ways. We routinely use two methods: a pressure pan and a duct blower with a blower door. A pressure pan is little more than a gasketed cover to place over supply and return registers. A tap on the top of the pan is attached to a hose that runs to a pressure gauge.

Here's how to conduct the test: With a blower door depressurizing the house to 25 pascals and with all the supply and return registers open, connect the pressure pan to a manometer (air-pressure gauge), and hold the pan tightly over a register. The negative pressure created by the blower door sucks air through all the leaks in the ductwork and then shows up as a reading from 1 to 25 pascals on the pressure gauge. Higher numbers indicate leakier ducts.

Of the two preferred methods, this test is quicker and easier to do. Pressure-pan testing is most useful where ducts are outside the thermal envelope: in crawlspaces, unconditioned basements, vented attics, and leaky floor cavities. If ducts are inside a conditioned basement, we open a basement door or window, which essentially puts the ductwork outside the thermal envelope.

Pressure-pan testing tells us where duct leakage is happening and which duct runs are the leakiest, but it does not determine the exact amount of air leakage. To quantify this leakage as outlined in the 2009 IRC and other building standards, we use a blower door with a duct blower.

A duct blower is a variable-speed fan that simulates normal duct pressure (25 pascals) when the HVAC system is operating. A pressure and flow gauge measures the amount of air going into the system and the amount leaking out.

To do this test, duct blowers can be installed at the furnace-blower compartment or in

the central return inside the home. Unfortunately, a duct-blower test by itself doesn't tell whether the ducts are leaking inside or outside the conditioned space, so we often use the duct blower in conjunction with a blower door.

We pressurize the house to 25 pascals with a blower door, tape off all supply and return registers, and then adjust the duct-blower fan speed until the duct and house pressures are the same. We place a probe from the pressure gauge into the supply ductwork to measure airflow. Any flow (measured in cfm) showing up on this gauge is air leaking to the outside.

Sometimes we use a theatrical fog machine in conjunction with the duct blower to locate the biggest duct leaks. The fog is a great way to see where to focus our sealing efforts. It can be tough to find companies doing duct testing, but some home-performance contractors, energy auditors, and forward-thinking HVAC companies conduct duct-tightness tests, especially in areas with strict code enforcement.

Where do ducts leak?

Ducts leak at nearly every seam and transition. Of course, it's easier to seal leaks in new construction before the walls are closed, so you should make every effort to see that this work is performed before you insulate the structure.

In older houses, you have to seal where you can. Unless there are huge problems, it probably doesn't make economic sense to open walls and ceilings for duct-sealing alone unless a deep-energy retrofit is planned. For existing homes, the best return on investment comes from sealing exposed ductwork in the attic and basement (or crawlspace).

Start with the big holes

The first priority should be to fix broken connections (often called disconnects). Disconnects can waste huge amounts of energy and make balancing air delivery to rooms nearly impossible. Common problems include missing end caps and filter slot covers, and separated floor and ceiling registers.

Next on the list is sealing leaks nearest to the air handler or furnace blower, including supply and return plenums, plenum connectors, and filter slots. These connections are under the highest pressure, making leaks more significant than in other parts of the system. Most important, return-duct leaks

anywhere combustion appliances are located can be dangerous. These leaks can contribute to a buildup of carbon monoxide when the resulting negative air pressure in the combustion area prevents flue gases from going up the chimney and instead brings the flue gases (including carbon monoxide) back into the house. This situation, called backdrafting, can be deadly.

Next in line of importance is sealing accessible connections between the duct sections, branches, and places where takeoffs connect to main trunk lines. It's also a good idea to seal any visible connections at register boots.

Screws, then mastic

The first step in sealing ducts is to make sure the parts are mechanically fastened to each other. Rectangular metal duct should be joined with manufacturer-specified connectors. Round ducts with crimped joints should have three screws evenly spaced around the circumference. Insulated flexible duct should use pairs of appropriately sized zip ties: one to secure the inner liner and a second around the insulation and outer jacket.

Once the connections are secured, gaps and seams should be coated with a thick layer of mastic. Any gaps larger than 1/8 in. wide first should be reinforced with fiberglass tape. Mastic can be gray, cream, or white to blend in with common HVAC-equipment colors. We like RCD products (www.rcdmastics.com), which we get from EFI (www.efi.org).

Applying duct mastic is easy. Sometimes it's painted on with a brush. More often, though, we wear latex gloves and put it on with our hands because it's easier to get the mastic on top of the ducts, especially when they're close to the ceiling or subfloor.

Some installers prefer duct tape because it's less messy. Aluminum tape is fine for fiberglass duct board and is good for air-handler cabinets because it's easy to remove for system repair. Butyl-backed aluminum tape is also becoming more popular. However, we find that the ducts must be spotless for the tape to stick permanently. Regular cloth-backed duct tape is never the right product for sealing ducts. □

A. Tamasin Sterner is president and chief coach of Pure Energy Coach in Lancaster, Pa. Larry Armanda is president of Therma-View Infrared and Energy Consultants in Williamsport, Pa. Photos by Patrick McCombe.

SEALING: Three strategies for airtight ductwork

Since ducts leak the most in areas under the greatest pressure, it makes sense to start at the blower cabinet and work out toward the registers. The best material for sealing is duct mastic, although foil tape can be used on areas that require system service. Small leaks are sealed with mastic alone, but larger holes (bigger than 1/8 in.) should be covered with fiberglass tape and then coated with mastic. Never use traditional cloth-backed duct tape for sealing ducts.



1 Use zip ties with flex ducts

Insulated flex ducts should be connected with pairs of zip ties pulled tight with a specialty tensioning tool or pliers. The first tie secures the inner liner, and a second secures the insulation and outer jacket.



2 Keep ductwork in conditioned spaces

Because leaky ducts in vented attics and crawlspaces waste more energy than leaky ducts inside the building, some energy-conscious builders and designers keep all ductwork within the conditioned space, usually inside drywall enclosures with taped joints.

CEILING BOOT

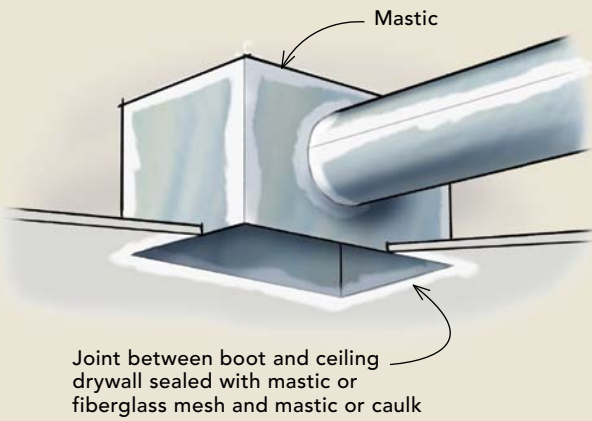

FLOOR BOOT

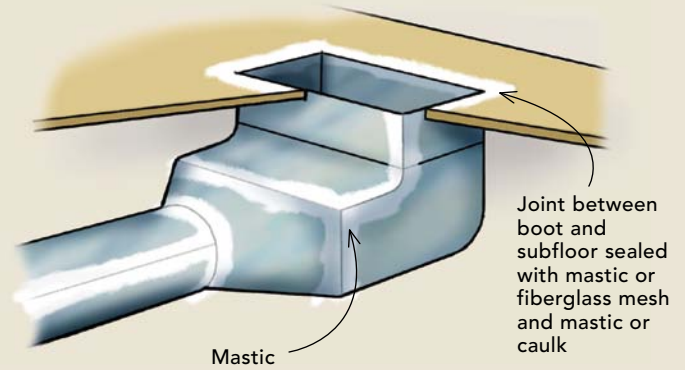

RIGID-TO-FLEX TRANSITION

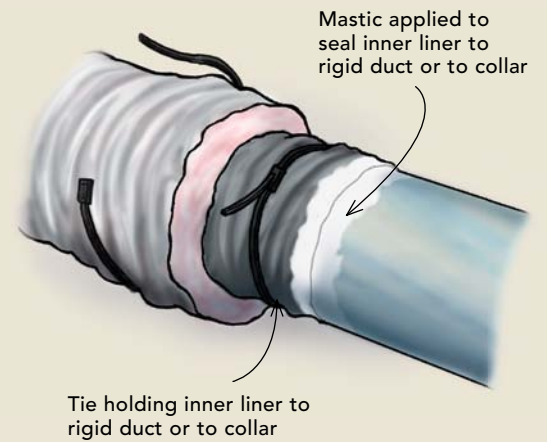

3 Seal subassemblies before installation

It's often impossible to get an adequate seal for ductwork that's pushed tight to framing members or buried in cluttered chases, so it's better to seal ducts and fittings before final installation. After dry-fitting, the parts can be removed and made into subassemblies of two to five parts, then sealed.



FLEX TAKEOFF FROM TRUNK LINE

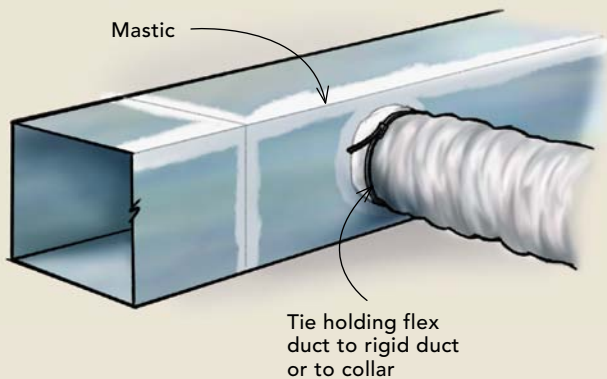

AIR HANDLER

